



# TxBLOCK-USB Transmitter

## TEMPERATURE TRANSMITTER – OPERATING MANUAL – V1.0x K

### INTRODUCTION

The **TxBLOCK-USB** is a 4-20 mA 2-wire temperature transmitter for head mount, powered by the current loop. The output current is linearized and adjusted in function of the input sensor type and range configured.

Its configuration is accomplished by connecting the transmitter to a PC USB port without the need of any dedicated interface. The configuration does not require that the transmitter be powered.

### MECHANICAL INSTALLATION

The **TxBLOCK-USB** transmitter is suitable to be installed in heads. Vibrations, moisture and extreme temperatures, electro-magnetic interference, high voltage and other interferences can permanently damage the unit, and could cause error in the measured value.

### DIMENSIONS:

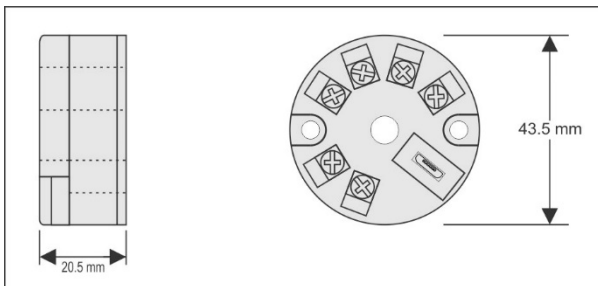

Fig. 1 – Transmitter dimensions

### ELECTRICAL INSTALLATION

- Section of the cable used: 0.14 to 1.5 mm<sup>2</sup>.
- Recommended torque in the terminal: 0.8 Nm.

### RECOMMENDATIONS FOR INSTALLATION

- Sensor signals conductors must go through the plant system separate from power leads (loop), if possible in grounded conduits.
- The instruments must be powered from the instrumentation power supply circuit.
- In control and monitoring applications is essential to consider what can happen when any part of the system fails.
- It is recommended the use of suppressors in contact coils, solenoids and any inductive load.

### ELECTRICAL CONNECTIONS

The figures below show the electrical connections required. The terminals 3, 4, 5 and 6 are dedicated to the sensor connection. **LOAD** represents the 4-20 mA current measuring device (indicator, controller, recorder, etc.).

### PT100 2-WIRE

**Note:** When the Pt100 2-wire is selected, the terminals 3 and 4 must be interconnected, according to the figure below.

The Pt100 wire length **should be less than 30 cm** to maintain the measurement error within specifications (electrical resistance).

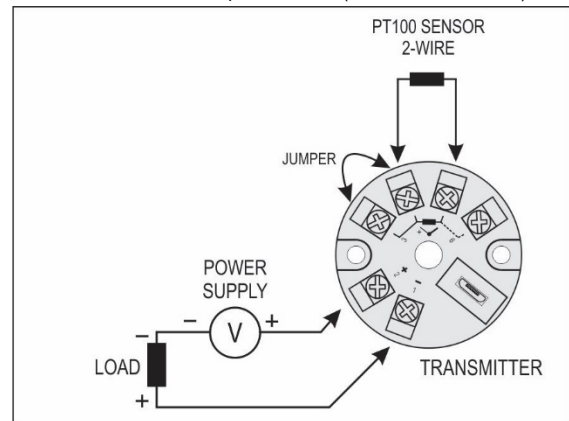

Fig. 2 – Transmitter electrical connections (Pt100 2-wire)

### PT100 3-WIRE

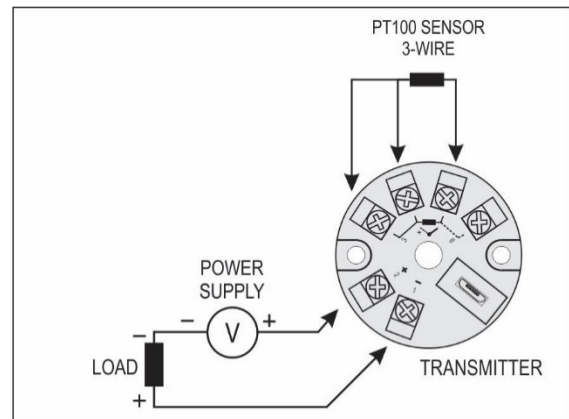

Fig. 3 – Transmitter electrical connections (Pt100 3-wire)

### PT100 4-WIRE

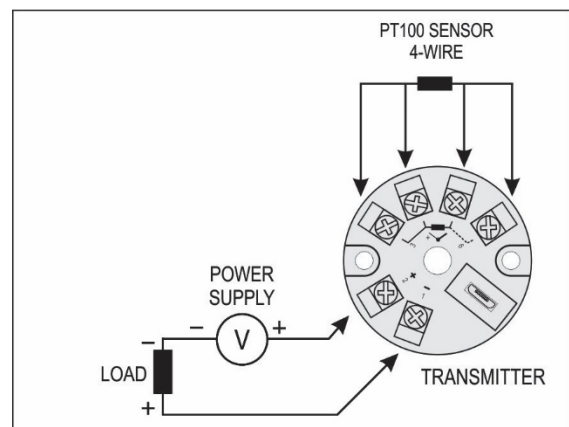

Fig. 4 – Transmitter electrical connections (Pt100 4-wire)

**Pt1000 3-wire / Pt100 3-wire and 4-wire:** For appropriate cable resistance compensation they should be equal for all legs. Maximum wire resistance is 25  $\Omega$  per wire leg. Usage of a 3 or 4 wire with conductors of equal length and gauge is recommended.

### NTC 2-WIRE

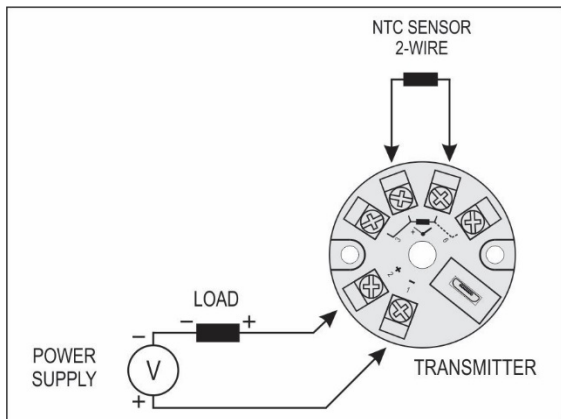

Fig. 5 – Transmitter electrical connections (NTC 2-wire)

### THERMOCOUPLES

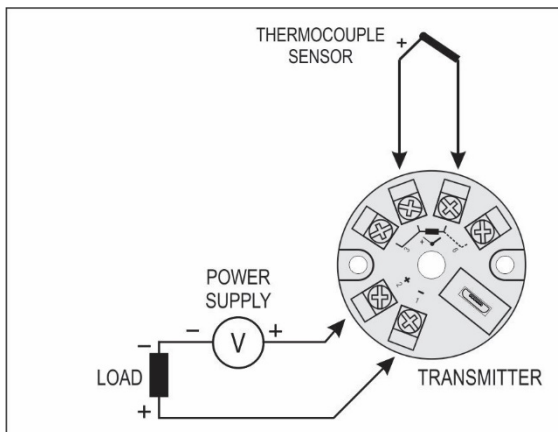

Fig. 6 – Transmitter electrical connections (Thermocouple)

### VOLTAGE (0-50 mV)

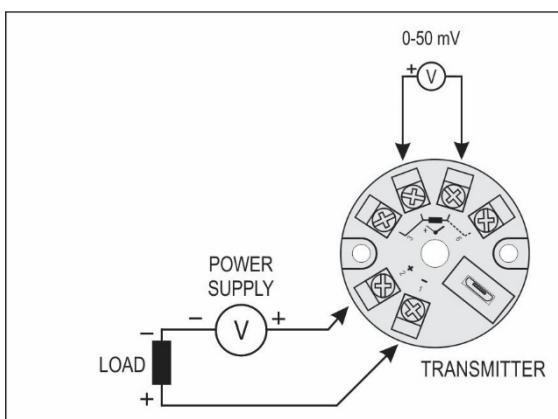

Fig. 7 – Transmitter electrical connections (0-50 mV)

## CONFIGURATION

When the transmitter is used with the factory setting, no further action is required and the transmitter is ready to be installed.

Changes to the configuration are possible through the **TxConfig II** software or the **TxConfig** application, provided free of charge.

The transmitter configuration interface (USB cable) can be purchased from the manufacturer or its authorized sales representatives.

The software is continuously updated and new versions can be downloaded at no charge from the manufacturer's website. To install, execute the **TxConfigIISetup.exe** file and follow the instructions.

The setup application is only available for Android smartphones and also can be downloaded for free in the Google Play Store. To configure the device through the application, an *On The Go* (OTG) adapter is required. The procedure for using this adapter will be explained throughout this manual.

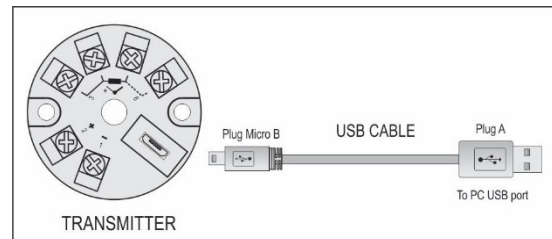

Fig. 8 – USB cable connection

During the setup, the transmitter is powered by the USB, not requiring an external power supply.

The transmitter setup can also be made by connecting it to the loop, using the *loop* power supply. There is no electrical insulation between the transmitter and the communication port (interface), therefore it is not recommended to configure it with the sensor inlet connected to the process. See Fig. 9.

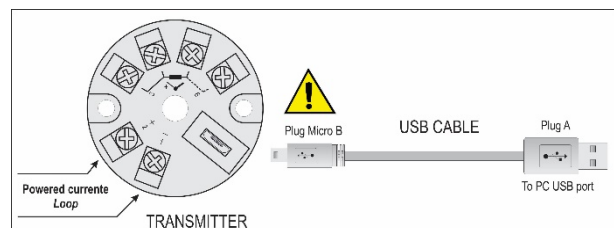

Fig. 9 – USB cable connections – Loop powered

After these connections, the user must run the **TxConfig II** software and, if necessary, consult the *Help* topic to help using the software.

For more information on how to connect the **TxBLOCK-USB** to the smartphone itself and to configure the device, see chapter **SMARTPHONE CONNECTIONS**.



The USB communication port (interface) of the **TxBLOCK-USB** is not electrically insulated from the transmitter's input.

## SOFTWARE AND APPLICATION CONFIGURATION:

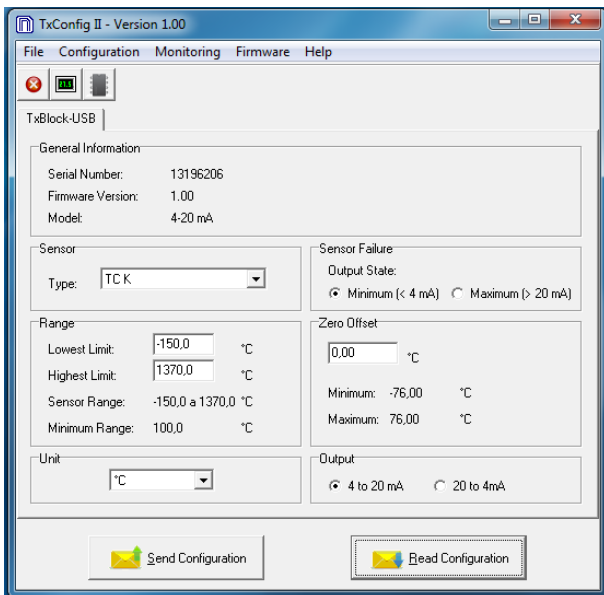

Fig. 10 – TxConfig II software main screen

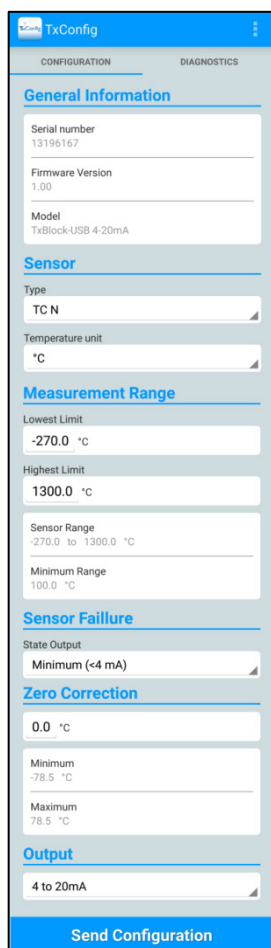

Fig. 11 – TxConfig application main screen

The fields in the screen mean:

- 1. General Information:** This field shows information that identifying the transmitter. This information should be sent to the manufacturer in an eventual request for technical assistance.
- 2. Sensor:** Select the type of sensor to be used. See **Table 1**.
- 3. Measuring Range:** Sets de measurement range of the transmitter.

**Lower Range Limit:** Equivalent temperature for a current of 4 mA.

**Upper Range Limit:** Equivalent temperature for a current of 20 mA.

## Sensor Range

The values chosen cannot exceed the **range of sensor** shown in this field. See **Table 1** of this manual.

## Minimum Range

Do not set a lower band (span) that the **Minimum Range** indicated below in this same field. See **Table 1** of this manual.

- 4. Sensor Failure:** It establishes the output behavior, when the transmitter indicates a failure:

**Minimum:** Output current goes to < 3.6 mA (down-scale), typically used for refrigeration.

**Maximum:** Output current goes to > 22.0 mA (up-scale), typically used for heating.

- 5. Zero Correction:** It corrects small deviations presented in the transmitter output, for example, when the sensor is replaced.

- 6. Send Configuration:** It applies the new setup. Once sent, the setup will be immediately adopted by the transmitter.

- 7. Read Configuration:** It reads the current setup in the transmitter connected. The screen now presents the current setup that may be changed by the user.

## FACTORY SETTING:

- Sensor: Pt100 3-wire, range 0 to 100 °C
- Sensor failure: upscale (maximum).
- 0 °C zero correction.
- Unit: °C;
- Output: 4-20 mA.

Upon purchase order, the user can define a specific setup.

## SMARTPHONE CONNECTIONS

With the help of a specific cable, which allows smartphones to recognize and configure **TxBLOCK-USB** when running the **TxConfig** application, Android smartphones with On the Go (OTG) technology can be directly connected to the device via the Micro-USB.

To do this, it is necessary to observe the connection mode of the cable On the Go in the device, as can be seen in **Fig. 12**:

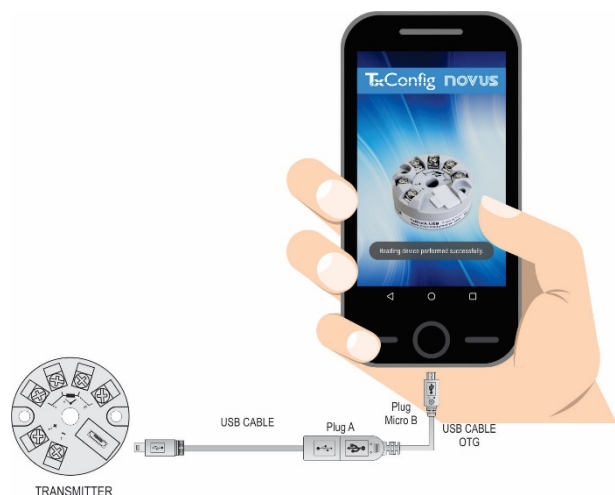

Fig. 12 – On the Go connection cable



If you position the cable end incorrectly, it is possible that the device will not be recognized by the application.

## CONFIGURING TXBLOCK-USB WITH TXCONFIG APPLICATION FOR ANDROID:

Once the connection between the smartphone and the **TxBLOCK-USB** is made, the device will send the following message:

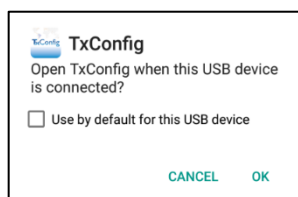

Fig. 13 – USB device connected

For the correct operation of the application, the option "Open TxConfig when this USB device is connected?" must be checked and then click the **OK** button.

After that, it will automatically run the **TxConfig** application, which has already been previously installed on the smartphone, and will display the following message:



Fig. 14 – Reading device

The application will automatically switch to the configuration screen (see Fig. 11), where it will be possible to configure the **TxBLOCK-USB**.

## OPERATION

The sensor offset can be changed through the **TxConfig II** software or the **TxConfig** app.

The USB cable may be connected to the transmitter without causing any measurement errors. See item *Zero Correction* in the chapter **CONFIGURATION** of this manual.

The user must choose the most suitable sensor and range to the process. The chosen range must not exceed the maximum range of measurement defined for the sensor and should not be smaller than the minimum range for the same sensor.

It is important to note that the transmitter accuracy is based on the maximum range of the sensor used, even when a narrower range is programmed.

### Example:

- The Pt100 sensor in the range 0 to 100 °C and accuracy of 0.12 %, the maximum error will be 1.02 °C (0.12 % de 850 °C).
- The Pt100 sensor in the range 500 to 600 °C and accuracy of 0.19 %, the maximum error will be 1.61 °C (0.19 % of the 850 °C).

**Note:** When measurements are made at the transmitter, see if the Pt100 excitation current required by the calibrator is compatible with the Pt100 excitation current used in the transmitter: 0.8 mA.

## SPECIFICATIONS

**Sensor input:** User defined. The supported sensors are listed in **Table 1**, along with their maximum ranges.

**Thermocouples:** Types J, K, R, S, T, N, E and B according to IEC 60584 (ITS-90). Impedance >> 1 M $\Omega$

**Pt100:** Type 3-wire, Excitation 0.8 mA,  $\alpha = 0.00385$ , according to IEC 60751 (ITS-90). For 2-wire sensors, tie terminals 3 and 4 together.

**Pt1000:** Type 3-wire, Excitation 0.65 mA,  $\alpha = 0.00385$ , according to IEC 60751 (ITS-90).

For 2-wire sensors, tie terminals 3 and 4 together.

**NTC R<sub>25°C</sub>:** 10 k $\Omega$   $\pm$  1 %, B<sub>25/85</sub> = 3435

**Voltage:** 0 to 50 mVdc. Impedance >> 1 M $\Omega$

| Sensor Type    | Maximum Measurement Range | Minimum Measurement Range |
|----------------|---------------------------|---------------------------|
| Voltage        | 0 to 50 mV                | 5 mV                      |
| Thermocouple K | -150 to 1370 °C           | 100 °C                    |
| Thermocouple J | -100 to 760 °C            | 100 °C                    |
| Thermocouple R | -50 to 1760 °C            | 400 °C                    |
| Thermocouple S | -50 to 1760 °C            | 400 °C                    |
| Thermocouple T | -160 to 400 °C            | 100 °C                    |
| Thermocouple N | -270 to 1300 °C           | 100 °C                    |
| Thermocouple E | -90 to 720 °C             | 100 °C                    |
| Thermocouple B | 500 to 1820 °C            | 400 °C                    |
| Pt100          | -200 to 650 °C            | 40 °C                     |
| Pt1000         | -200 to 650 °C            | 40 °C                     |
| NTC            | -30 to 120 °C             | 40 °C                     |

Table 1 – Sensors accepted by the transmitter

**Switch-on delay:** < 2.5 s. The accuracy is only guaranteed after 15 minutes.

**Terms of reference:** Ambient: 25 °C; voltage: 24 Vdc, load: 250  $\Omega$ ; settling time: 15 minutes.

**Temperature Effect:** <  $\pm$ 0.16 % / 25 °C

**Response time:** Typical 1.6 s

**Maximum voltage allowed at sensor input terminals:** 3 V

**RTD current:** 800  $\mu$ A

**RTD cable resistance effect:** 0.005 °C /  $\Omega$

**Maximum allowable cable resistance for RTD:** 25  $\Omega$

| Sensor Type                     | Typical Accuracy | Minimum Accuracy |
|---------------------------------|------------------|------------------|
| Pt100 / Pt1000 (-150 to 400 °C) | 0.10 %           | 0.12 %           |
| Pt100 / Pt1000 (-200 to 650 °C) | 0.13 %           | 0.19 %           |
| mV, K, J, T, E, N, R, S, B      | 0.1 % (*)        | 0.15 % (*)       |
| NTC                             | 0.3 °C           | 0.7 °C           |

Table 2 – Calibration error, percentage of the full measurement range

(\*) Add cold junction compensation:  $\pm$  1 °C

**Power supply influence:** 0.006 % / V typical (percentage of the full measure range).

**Output:** 4-20 mA or 20-4 mA current, 2-wired; linear in relation to the temperature measurement by the selected sensor.

**Output Resolution:** 2  $\mu$ A

**Power supply:** 10 to 35 Vdc, across the transmitter

**Maximum load (RL):** RL (max.) = (Vdc – 10) / 0.02 [ $\Omega$ ]

Where: Vdc= Power supply voltage (10-35 Vdc)

**Operating Temperature:** -40 to 85 °C

**Humidity:** 0 to 90 % RH

**Electromagnetic Compatibility:** EN 61326-1:2006

**No electrical isolation between input and output.**

**Internal protection against polarity inversion.**

**Cold junction compensation for thermocouples.**

**Dimensions:** 43.5 mm (diameter) x 20.5 mm (height)

**Connection Wire Cross Section:** 0.14 a 1.5 mm<sup>2</sup>

**Screw Tightening:** 0.8 Nm

**Housing:** ABS UL94-HB

## WARRANTY

Warranty conditions are available on our website  
[www.novusautomation.com/warranty](http://www.novusautomation.com/warranty).